

Fibre Switching Unit Actuator for the LISA mission



Jiří Svoboda

Astronomical institute of the Czech Academy of Sciences



Michael Prouza, Libor Švéda

Institute of Physics of the Czech Academy of Sciences



Miroslav Chomát

Institute of Thermomechanics of the Czech Academy of Sciences



Jan Souček

Institute of Atmospheric Physics of the Czech Academy of Sciences

FSUA system

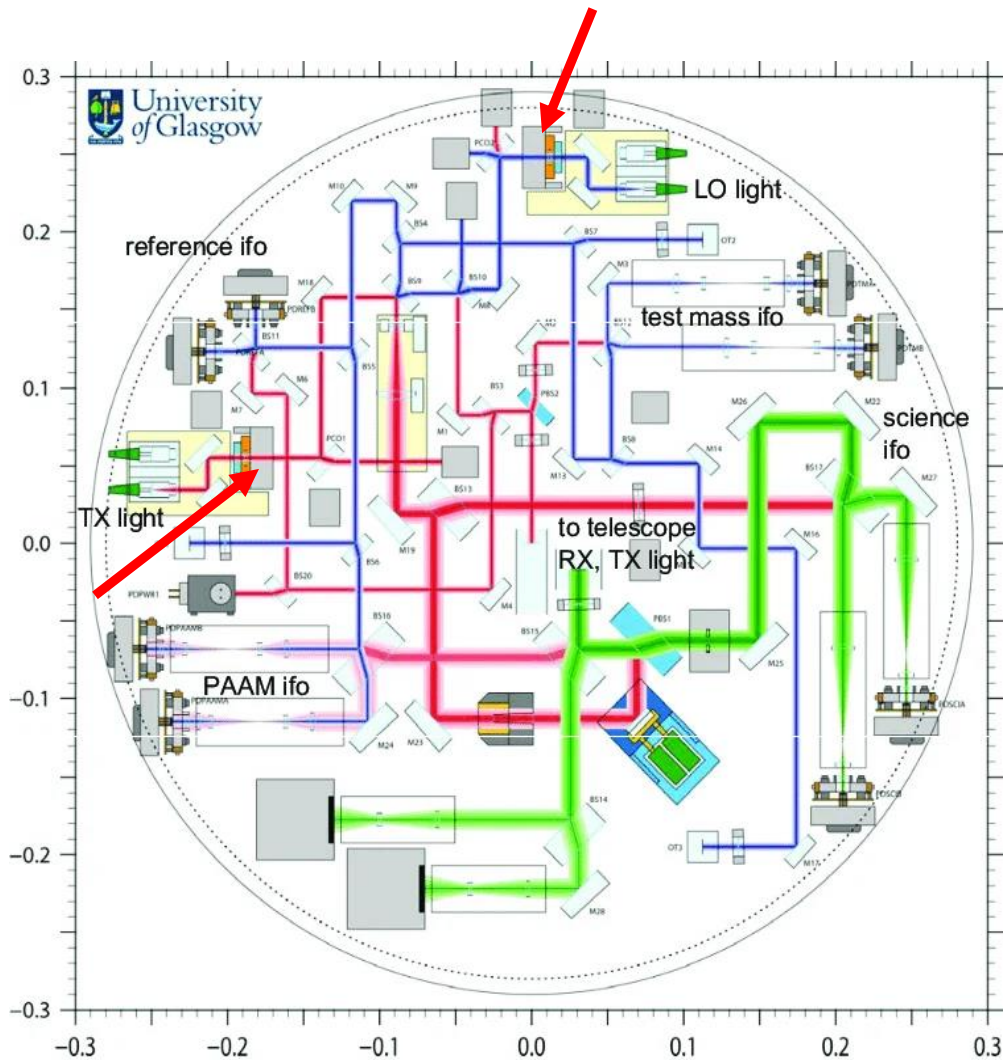

- FSUA = Fibre Switch Unit Actuator
- A small piezo-electric mechanism rotating polarization of the laser beam

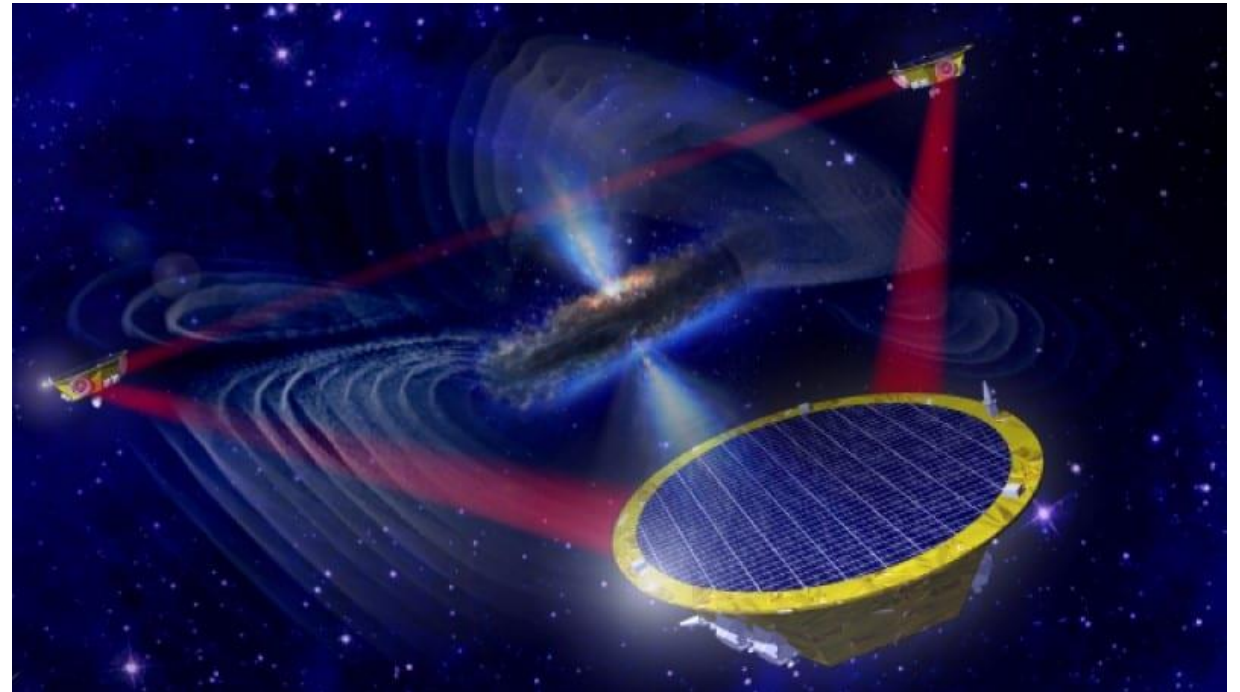
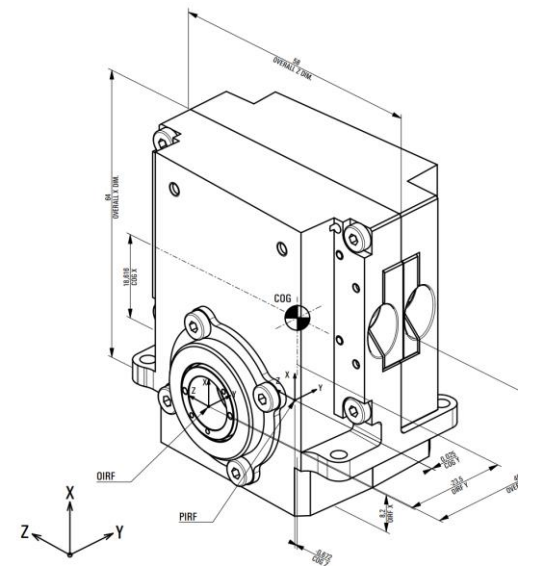

Equipment to be developed by the Czech team

The FSUA mechanism: A tiny, sophisticated mechanism including piezo driver, position sensor and fine mechanics

Front End Electronics: A circuit board inside the **OBMCU** Optical Bench Mechanism Control Unit, driving the mechanism and performing position readout

The OBMCU box: A mechanical enclosure, housing the FSUA FEE and also control electronics for other mechanisms.

- There are many units to be built and tested (~18 redundant FSUA mechanisms and 15 FEE boards)
- Qualification model planned in 2029, Flight model build starting from 2030.

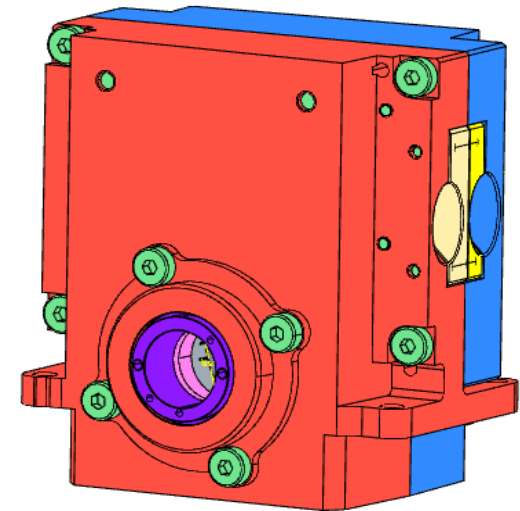
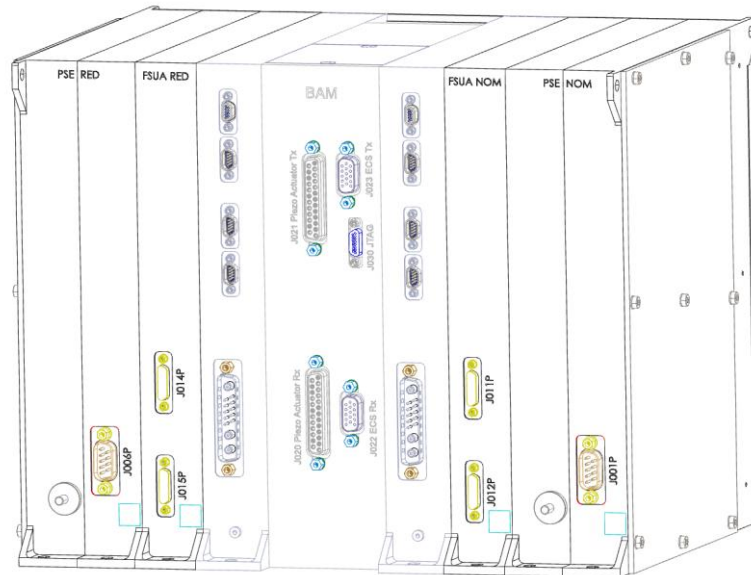
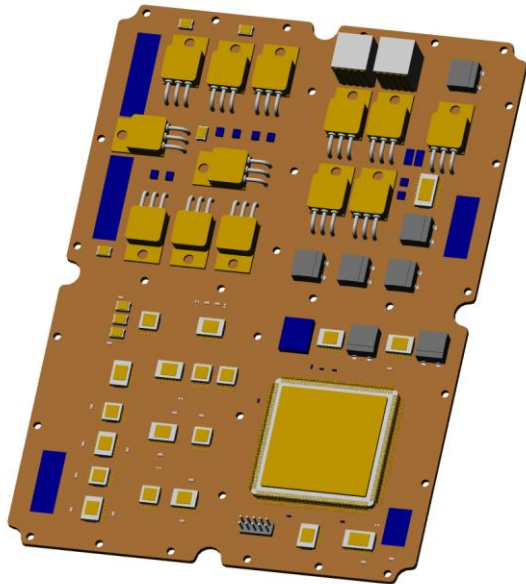

Equipment to be developed by the Czech team

- Project is now at preliminary design review (PDR)
- Engineering manufacturing starting soon

Technology development, prototyping and EM build done at the Academy of Sciences

For qualification and flight models, more industrial involvement is needed

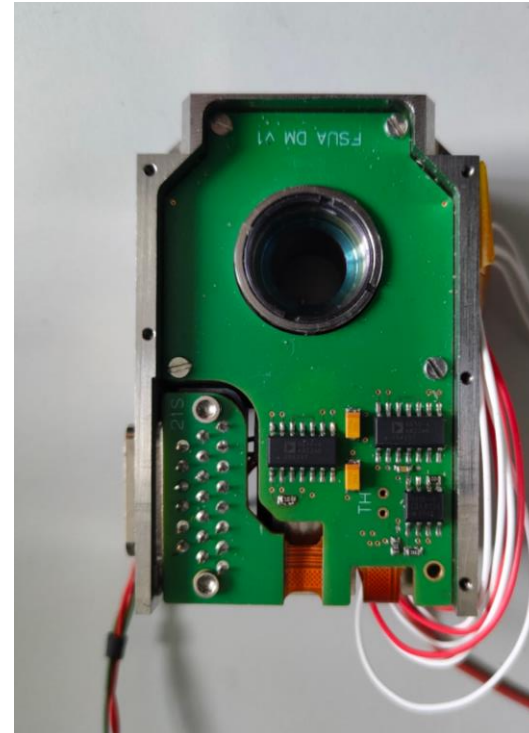
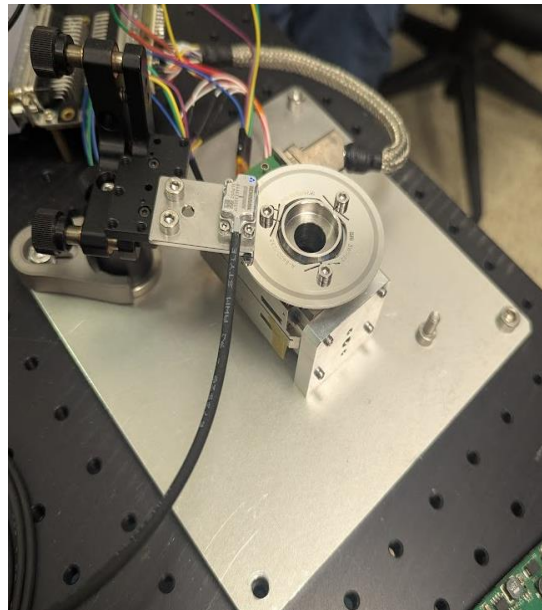
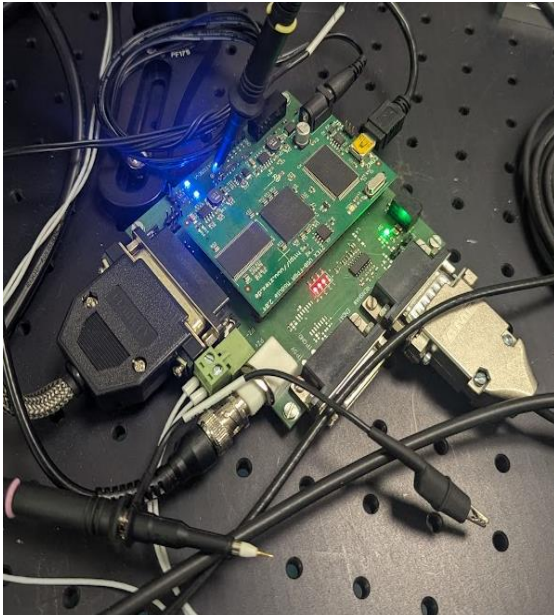

FSUA mechanism – procurement

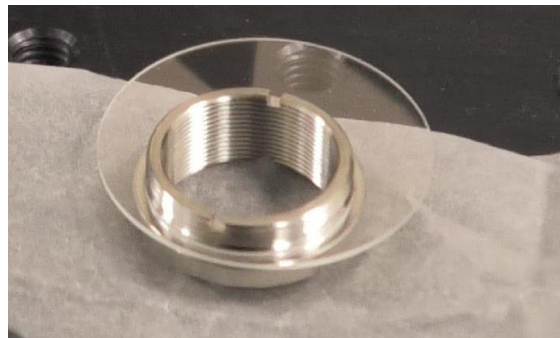
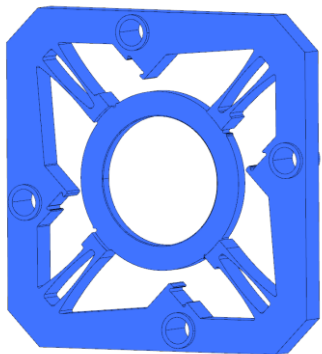
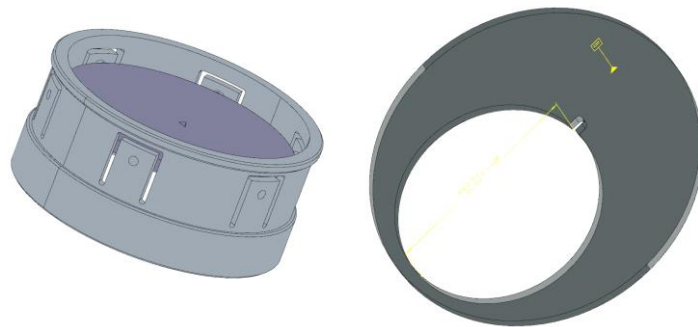
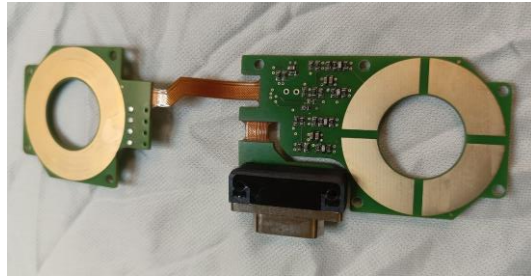
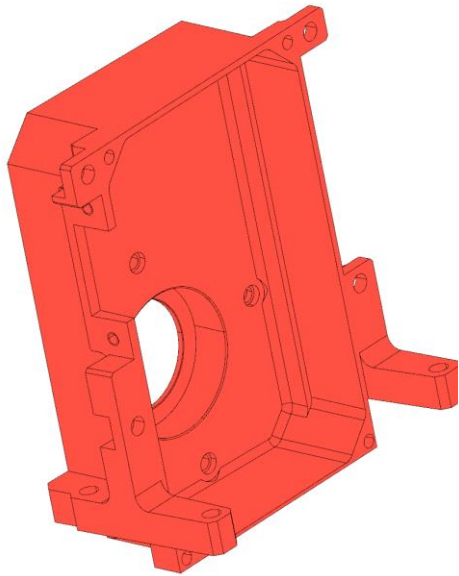

Mechanical parts manufacturing

- Precision Ti gr 5
- PEEK CA30

Mechanical components

- Ti screws, MoS2 coated
- Fused silica excentric encoder rotors

Electronic parts

- Components – Procured via ESA CPPA
- Hybrid Rigid/Flex PCBs (ECSS qualified)
- Pigtail cables
- PCB assembly

Services

- Mechanical tests (sine, shock, random), ISO5
- Optical element gluing (centroscope)
- Degaussing, ISO5
- Outgassing measurements

OBMCU housing – procurement

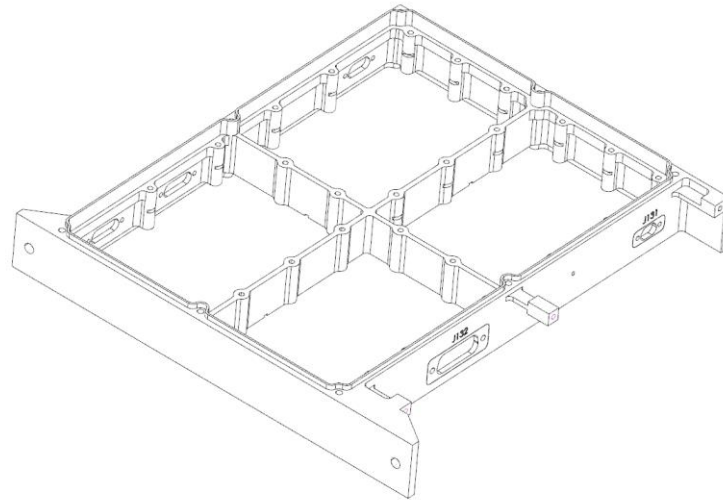
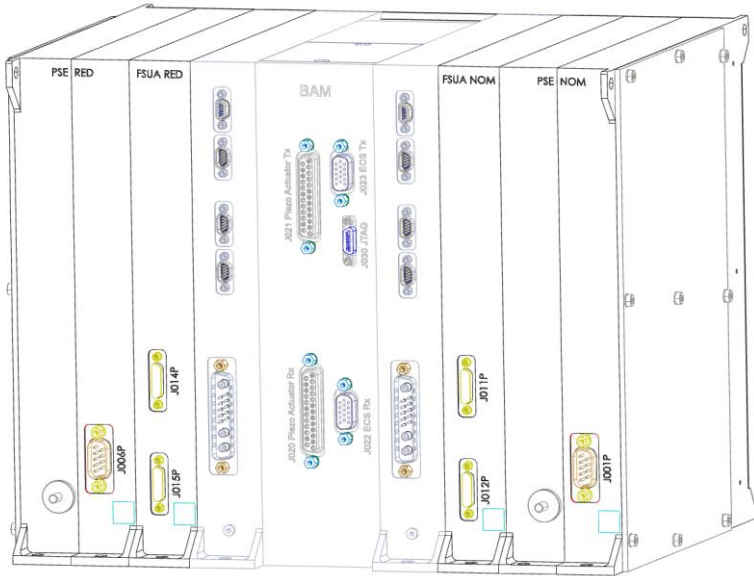

Mechanical parts manufacturing

- *Aluminum alloy + Surtec +650 bronze helicoils*
- *EN AW 2023*
- *SS rods and screws*

Services

- *Mechanical tests (sine, shock, random), ISO8 cleanroom*
- *Thermal vacuum tests, ISO8 cleanroom*

FSUA-FEE – procurement

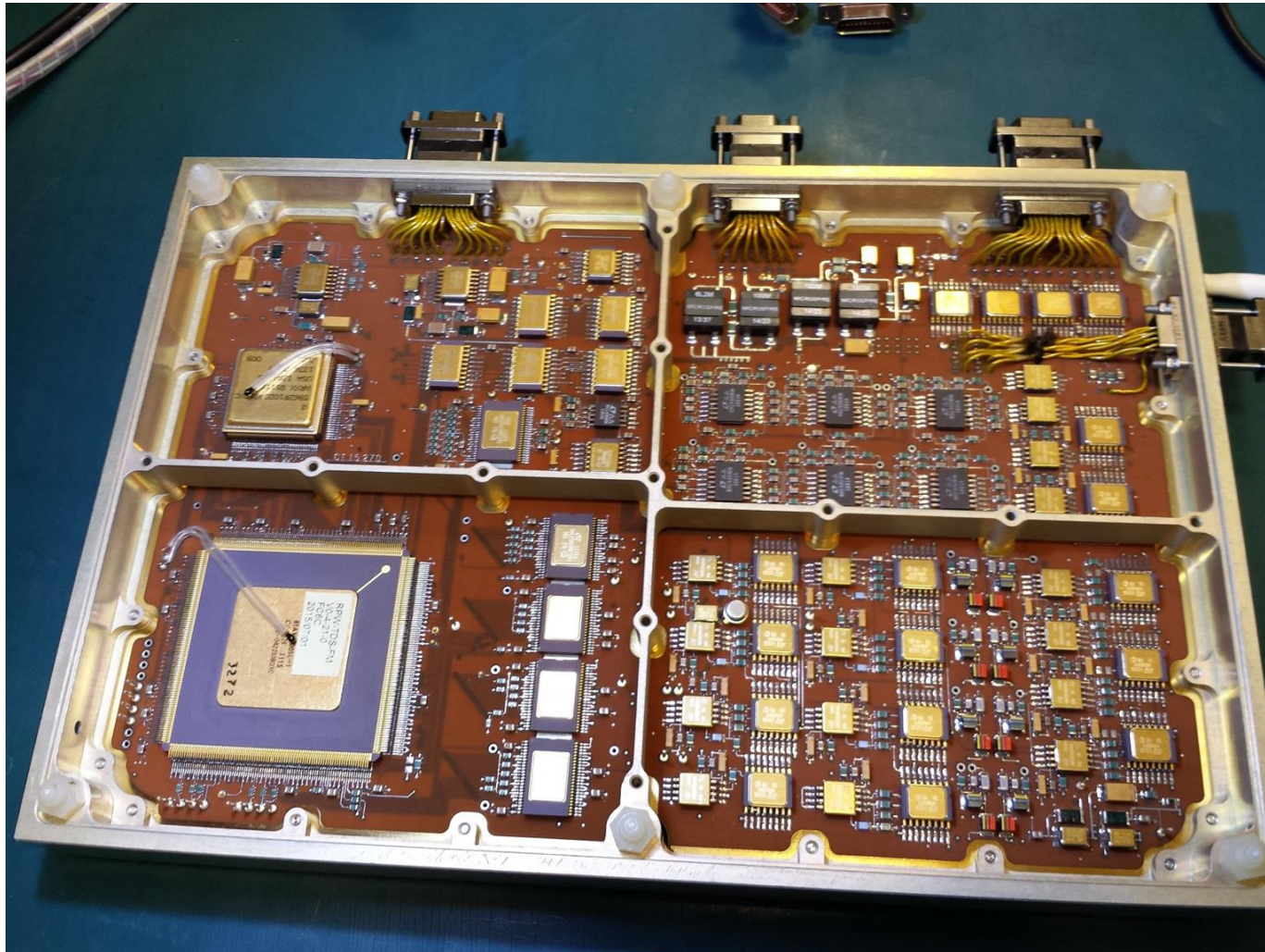

EEE parts and PCBs procured by FSUA consortium

Qualification Model (2028/29):

- *designed by FSUA consortium*
- *fully manufactured by industry*
- *Testing and calibration performed jointly by FSUA consortium and industry. - Test procedure developed and automated.*

Flight models (2029 +):

- *Manufacturing and testing of electronics entirely by industry. Finished items delivered to FSUA consortium.*